

GRP backing flanges made of Polyester resin.

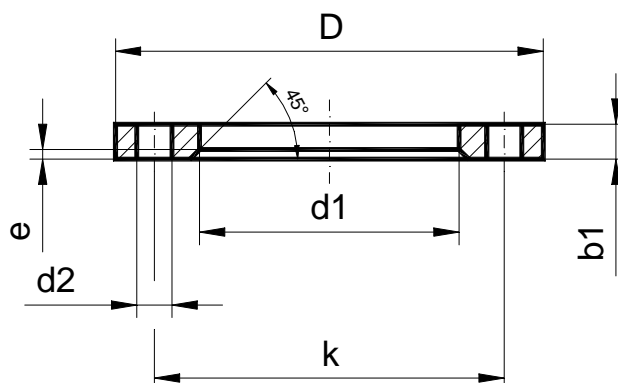

Flange connecting dimensions according to DIN 2501 Part 1, PN10

DN [mm]	D [mm]	k [mm]	d1 [mm]	d2 [mm]	e [mm]	Number of drills	Bolts size	maximum allowable working pressure	
								b1 [mm]	PN [bar]
25	115	85	50,5	14	3,5	4	M12	14	16
32	140	100	58,5	18	3,5	4	M16	15	16
40	150	110	68,5	18	3,5	4	M16	16	16
50	165	125	82,5	18	3,5	4	M16	18	16
65	185	145	95,5	18	3,5	4	M16	20	10
80	200	160	111,5	18	3,5	8	M16	22	10
100	220	180	133,5	18	4,5	8	M16	24	10
125	250	210	160,5	18	4,5	8	M16	27	10
150	285	240	188,5	22	4,5	8	M20	30	10
200	340	295	238	22	6	8	M20	32	6
250	395	350	294	22	6	12	M20	34	6
300	445	400	344	22	6	12	M20	36	6
350	505	460	388	22	7	16	M20	38	4
400	565	515	442	26	7	16	M24	42	4
500	670	620	545	26	7	20	M24	47	4

GRP backing flanges made of Polyester resin.

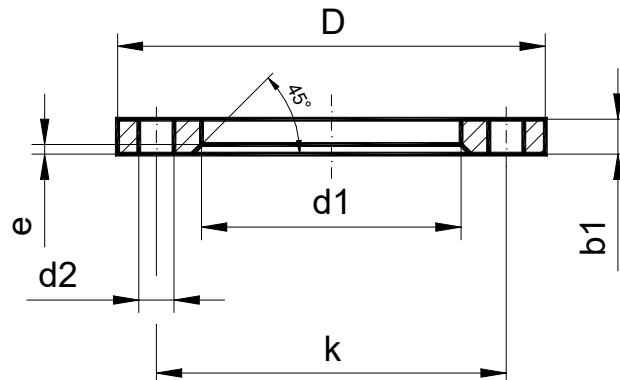

Flange connecting dimensions according to DIN 2501 Part 1, PN10
Nominal pressure PN 10

								maximum allowable working pressure	
DN [mm]	D [mm]	k [mm]	d1 [mm]	d2 [mm]	e [mm]	Number of drills	Bolts size	b1 [mm]	PN [bar]
25	115	85	50,5	14	3,5	4	M12	14	16
32	140	100	58,5	18	3,5	4	M16	15	16
40	150	110	68,5	18	3,5	4	M16	16	16
50	165	125	82,5	18	3,5	4	M16	18	16
65	185	145	95,5	18	3,5	4	M16	20	10
80	200	160	111,5	18	3,5	8	M16	22	10
100	220	180	133,5	18	4,5	8	M16	24	10
125	250	210	160,5	18	4,5	8	M16	27	10
150	285	240	188,5	22	4,5	8	M20	33	10
200	340	295	238	22	6	8	M20	41	10
250	395	350	294	22	6	12	M20	51	10
300	445	400	344	22	6	12	M20	59	10
350	505	460	388	22	7	16	M20	63	10
400	565	515	442	26	7	16	M24	72	10

The grey marked values are different to 1310-WN-en.

Backing flanges made of steel S235JR (St37-2).

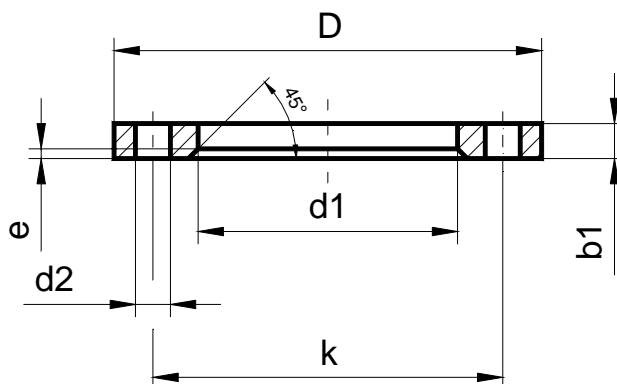

The standard corrosion protection is hot dip galvanized.
Other corrosion protection by request.

							PN	10
								[bar]
DN	D	k	d1	d2	e	Number of drills	Screw metric	b1
[mm]	[mm]	[mm]	[mm]	[mm]	[mm]			[mm]
25	115	85	50,5	14	3	4	M 12	16
32	140	100	58,5	18	3	4	M 16	18
40	150	110	68,5	18	3	4	M 16	18
50	165	125	82,5	18	3	4	M 16	20
65	185	145	95,5	18	3	4 / 8*	M 16	20
80	200	160	111,5	18	3	8	M 16	20
100	220	180	133,5	18	3	8	M 16	22
125	250	210	160,5	18	3	8	M 16	22
150	285	240	188,5	22	3	8	M 20	24
200	340	295	238	22	4	8	M 20	24**
250	395	350	294	22	4	12	M 20	26**
300	445	400	344	22	4	12	M 20	26
350	505	460	388	22	4	16	M 20	30
400	565	515	442	26	4	16	M 24	32
450	615	565	500	26	4	20	M 24	36
500	670	620	545	26	4	20	M 24	38
600	780	725	650	30	4	20	M 27	42**
712	895	840	765	30	4	24	M 27	50**
800	1015	950	860	33	4	24	M 30	56**
900	1115	1050	962	33	4	28	M 30	62**
1000	1230	1160	1062	36	4	28	M 33	70**

* Steel flanges with 4 holes are needed, these can be delivered according to agreement between manufacturer and purchaser.

** Thickness (b1) is different than DIN Standard 16966 part 6

Backing flanges made of steel ASTMA 105.

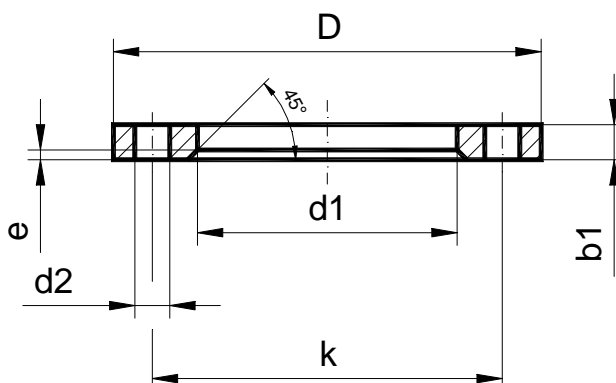

The standard corrosion protection is hot dip galvanized.
 Other corrosion protection by request.

Flange connecting dimensions up to 24": according ANSI B16,5 - 150 lbs
 >24" according to BS 3293-1960

DN [Inch]	D [mm]	k [mm]	d1 [mm]	d2 [mm]	e [mm]	Number of drills	PN Screw Inch	150 [lbs] b1 [mm]
1"	108	79,4	50,5	16	3	4	1/2"	14
1 1/4"	117	88,9	58,5	16	3	4	1/2"	16
1 1/2"	127	98,4	68,5	16	3	4	1/2"	18
2"	152	120,6	82,5	19	3	4	5/8"	19
2 1/2"	178	139,7	95,5	19	3	4	5/8"	22
3"	190	152,4	111,5	19	3	4	5/8"	24
4"	229	190,5	133,5	19	3	8	5/8"	24
5"	254	216	160,5	22,5	3	8	3/4"	24
6"	279	241,3	188,5	22,5	3	8	3/4"	25
8"	343	298,4	238	22,5	4	8	3/4"	29
10"	406	362	294	25,5	4	12	7/8"	30
12"	483	431,8	344	25,5	4	12	7/8"	32
14"	533	476,2	388	29	4	12	1"	35
16"	597	539,7	442	29	4	16	1"	37
18"	635	577,8	500	32	4	16	1 1/8"	40
20"	698	635	545	32	4	20	1 1/8"	43
22"	749	692	600	35	4	20	1 1/4"	46
24"	813	749	650	35	4	20	1 1/4"	48
28"	927	864	765	35	4	28	1 1/4"	52
32"	1060	978	860	41,5	4	28	1 1/2"	57
36"	1168	1086	962	41,5	4	32	1 1/2"	60
40"	1289	1200	1062	41,5	4	36	1 1/2"	63
42"	1346	1257	1120	41,5	4	36	1 1/2"	67

Pipe type BK

Specific values Epoxy Vinyl Ester Resin Bisphenol-A Base

Tensile strength N/mm ²	165
Tensile elasticity modulus N/mm ²	12500
Bending strength N/mm ²	200
Bending elasticity modulus N/mm ²	11500
A1 I = A 1 B (valid for 2*10 ⁵ h)	1,55
A2	s. DIBt Media list
A3	s. WN 2041
A4	1,0
Density g/cm ³	1,6
Breaking load of laminate connections N/mm ²	165
Thermal conductivity W/mK	0,24
Coefficient of linear expansion	21 x 10 ⁻⁶ x 1/K
Barcol hardness	> 35
Styrene content after heat treatment %	< 2

UP – resins based pipes, glass reinforced with thermoplastic liner.
Wall thickness S3 [mm] according material certificate.
Mechanical layer according pipe class BK (see 1270-WN).
Complete pipe lengths are provided with 20 mm not laminated pipe ends.

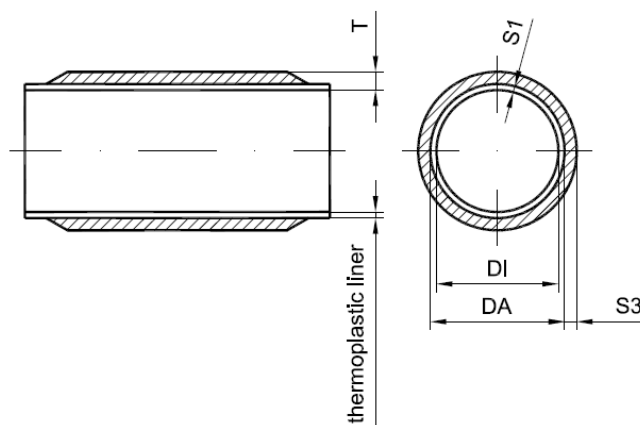

DN	PP fabric backed			PN6 [bar]		PN10 [bar]		PN16 [bar]	
	DA x S1 [mm]	SDR	DI [mm]	S3 [mm]	T [mm]	S3 [mm]	T [mm]	S3 [mm]	T [mm]
25	32 x 2,9	11	26,2					2,9	5,8
32	40 x 3,7	11	32,6					2,9	6,6
40	50 x 4,6	11	40,8					2,9	7,5
50	63 x 5,8	11	51,4					2,9	8,7
65	75 x 4,3	17,6	66,4					2,9	7,2
80	90 x 5,1	17,6	79,8					2,9	8,0
100	110 x 6,3	17,6	97,4			2,9	9,2	3,5	9,8
125	125 x 7,1	17,6	110,8			2,9	10,0	4,1	11,2
150	160 x 4,9	33	150,2	2,9	7,8	3,5	8,4	4,9	9,8
200	200 x 6,2	33	187,6	2,9	9,1	4,1	10,3	6,3	12,5
250	250 x 6,2	41	237,6	2,9	9,1	4,9	11,1	7,7	13,9
300	315 x 7,7	41	299,6	3,5	11,2	6,3	14,0	9,7	17,4
350	355 x 6,0	41	343	4,1	10,1	6,9	12,9	11,2	17,2
400	400 x 6,0	Lü.R.	388	4,9	10,9	7,7	13,7	12,6	18,6
500	508 x 4,0	Pl.	500	6,3	10,3	9,7	13,7	15,4	19,4
600	608 x 4,0	Pl.	600	6,9	10,9	12,0	16,0	18,2	22,2
700	720 x 4,0	Pl.	712	8,3	12,3	13,4	17,4		
800	808 x 4,0	Pl.	800	9,1	13,1	15,4	19,4		
900	908 x 4,0	Pl.	900	10,5	14,5	16,8	20,8		
1000	1008 x 4,0	Pl.	1000	11,2	15,2	19,0	23,0		

S1 = thickness of thermoplastic liner
S3 = wall thickness of structural laminate
Lü.R = series of ventilation
Pl. = slab with longitudinal weld

UP – resins based pipes, glass reinforced with thermoplastic liner.
Wall thickness S3 [mm] according material certificate.
Mechanical layer according pipe class BK (see 1270-WN).
Complete pipe lengths are provided with 20 mm not laminated pipe ends.

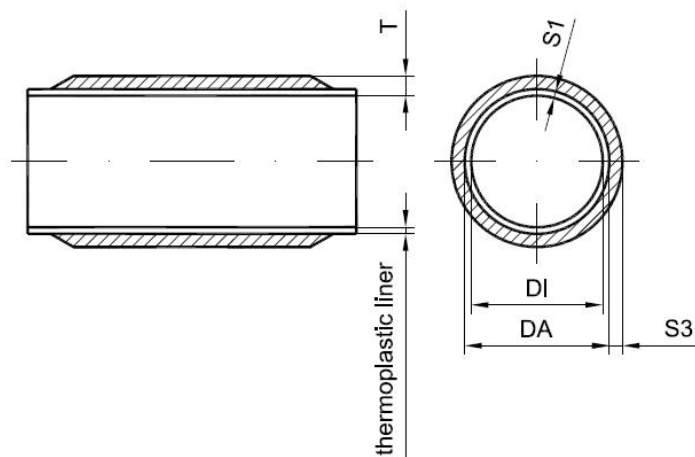

PE fabric backed				PN6 [bar]		PN10 [bar]		PN16 [bar]	
DN	DA x S1 [mm]	SDR	DI [mm]	S3 [mm]	T [mm]	S3 [mm]	T [mm]	S3 [mm]	T [mm]
25	32 x 3,0	11	26,2					2,9	5,9
32	40 x 3,7	11	32,6					2,9	6,6
40	50 x 4,6	11	40,8					2,9	7,5
50	63 x 5,8	11	51,4					2,9	8,7
65	75 x 4,5	17	66					2,9	7,4
80	90 x 5,4	17	79,2					2,9	8,3
100	110 x 6,6	17	96,8			2,9	9,5	3,5	10,1
125	125 x 4,8	26	115,4			2,9	7,7	4,1	8,9
150	160 x 4,9	33	150,2	2,9	7,8	3,5	8,4	4,9	9,8
200	200 x 6,2	33	187,6	2,9	9,1	4,1	10,3	6,3	12,5
250	250 x 6,2	41	237,6	2,9	9,1	4,9	11,1	7,7	13,9
300	315 x 7,7	41	299,6	3,5	11,2	6,3	14,0	9,7	17,4
350	355 x 8,7	41	337,6	4,1	12,8	6,9	15,6	11,2	19,9
400	400 x 8,0	Lü.R.	384	4,9	12,9	7,7	15,7	12,6	20,6
500	508 x 4,0	Pl.	500	6,3	10,3	9,7	13,7	15,4	19,4
600	608 x 4,0	Pl.	600	6,9	10,9	12,0	16,0	18,2	22,2
700	720 x 4,0	Pl.	712	8,3	12,3	13,4	17,4		
800	808 x 4,0	Pl.	800	9,1	13,1	15,4	19,4		
900	908 x 4,0	Pl.	900	10,5	14,5	16,8	20,8		
1000	1008 x 4,0	Pl.	1000	11,2	15,2	19,0	23,0		

S1 = thickness of thermoplastic liner
S3 = wall thickness of structural laminate
Lü.R. = series of ventilation
Pl.= slab with longitudinal weld

UP – resins based pipes, glass reinforced with thermoplastic liner.
Wall thickness S3 [mm] according material certificate.
Mechanical layer according pipe class BK (see 1270-WN).
Complete pipe lengths are provided with 20 mm not laminated pipe ends.

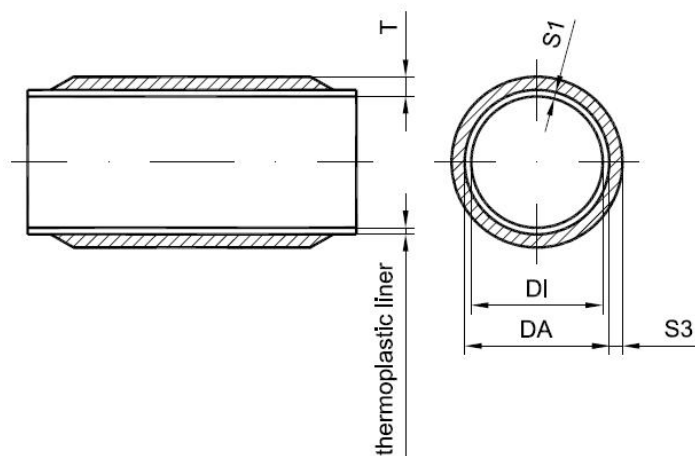

PVC-U Rohre				PN6 [bar]		PN10 [bar]		PN16 [bar]	
	rot	grau							
DN	DA x S1 [mm]	DA x S1 [mm]	DI [mm]	S3 [mm]	T [mm]	S3 [mm]	T [mm]	S3 [mm]	T [mm]
25	32 x 3,6	=	24,8					2,9	6,5
32	40 x 4,5	=	31					2,9	7,4
40	50 x 3,7	=	42,6					2,9	6,6
50	63 x 4,7	=	53,6					2,9	7,6
65	75 x 3,6	=	67,8					2,9	6,5
80	90 x 4,3	=	81,4					2,9	7,2
100	110 x 5,3	=	99,4			2,9	8,2	3,5	8,8
125	125 x 3,7	=	117,6			2,9	6,6	4,1	7,8
150	160 x 4,7	=	150,6	2,9	7,6	3,5	8,2	4,9	9,6
200	200 x 4,0	=	192	2,9	6,9	4,1	8,1	6,3	10,3
250	250 x 4,9	=	240,2	2,9	7,8	4,9	9,8	7,7	12,6
300	315 x 4,5	315 x 6,2	-	3,5	8,0	6,3	10,8	9,7	14,2
350	355 x 4,5	355 x 4,4	-	4,1	8,6	6,9	11,4	11,2	15,7
400	400 x 5,0	=	390	4,9	9,9	7,7	12,7	12,6	17,6
500	500 x 5,0	500 x 5,6	-	6,3	11,3	9,7	14,7	15,4	20,4
600	600 x 5,0	600 x 5,0	-	6,9	11,9	12,0	17,0	18,2	23,2
700	720 x 4,0	=	712	8,3	12,3	13,4	17,4		
800	808 x 4,0	=	800	9,1	13,1	15,4	19,4		
900	908 x 4,0	=	900	10,5	14,5	16,8	20,8		
1000	1008 x 4,0	=	1000	11,2	15,2	19,0	23,0		

S1 = thickness of thermoplastic liner
S3 = wall thickness of structural laminate
Slab with longitudinal weld

UP – resins based pipes, glass reinforced with thermoplastic liner.
Wall thickness S3 [mm] according material certificate.
Mechanical layer according pipe class BK (see 1270-WN).
Complete pipe lengths are provided with 20 mm not laminated pipe ends.

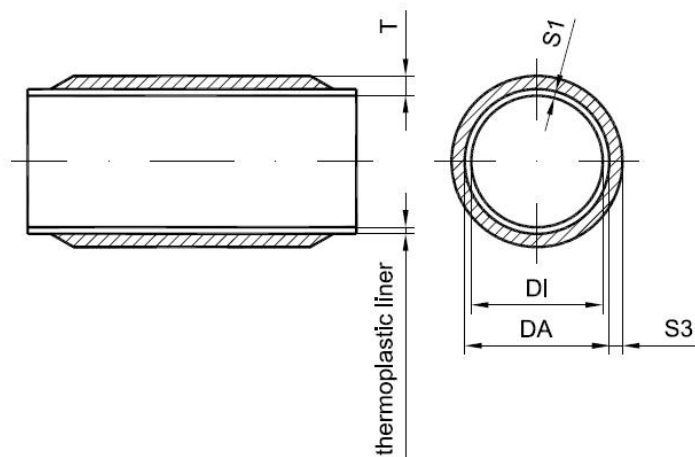

DN	PVC-C		PN6 [bar]		PN10 [bar]		PN16 [bar]	
	DA x S1 [mm]	DI [mm]	S3 [mm]	T [mm]	S3 [mm]	T [mm]	S3 [mm]	T [mm]
25	32 x 3,6	24,8					2,9	6,5
32	40 x 4,5	31					2,9	7,4
40	50 x 3,7	42,6					2,9	6,6
50	63 x 4,7	53,6					2,9	7,6
65	75 x 3,6	67,8					2,9	6,5
80	90 x 4,3	81,4					2,9	7,2
100	110 x 5,3	99,4			2,9	8,2	3,5	8,8
150	160 x 4,7	150,6	2,9	7,6	3,5	8,2	4,9	9,6
200	200 x 4,0	192	2,9	6,9	4,1	8,1	6,3	10,3
250	250 x 4,9	240,2	2,9	7,8	4,9	9,8	7,7	12,6
300	315 x 4,5	306	3,5	8,0	6,3	10,8	9,7	14,2
350	355 x 4,5	346	4,1	8,6	6,9	11,4	11,2	15,7
400	400 x 5,0	390	4,9	9,9	7,7	12,7	12,6	17,6
500	500 x 5,0	490	6,3	11,3	9,7	14,7	15,4	20,4
600	600 x 5,0	590	6,9	11,9	12,0	17,0	18,2	23,2
700	720 x 4,0	712	8,3	12,3	13,4	17,4		
800	808 x 4,0	800	9,1	13,1	15,4	19,4		
900	908 x 4,0	900	10,5	14,5	16,8	20,8		
1000	1008 x 4,0	1000	11,2	15,2	19,0	23,0		

S1 = thickness of thermoplastic liner
S3 = wall thickness of structural laminate
Slab with longitudinal weld

UP – resins based pipes, glass reinforced with thermoplastic liner.
Wall thickness S3 [mm] according material certificate.
Mechanical layer according pipe class BK (see 1270-WN).
Complete pipe lengths are provided with 20 mm not laminated pipe ends.

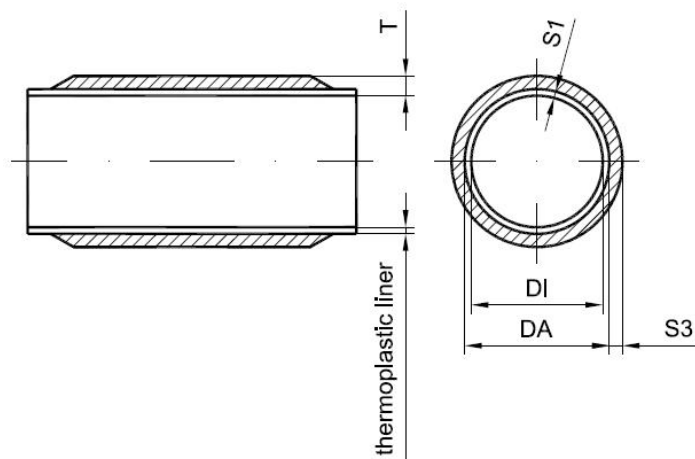

DN	PVDF etched		PN6 [bar]		PN10 [bar]		PN16 [bar]	
	DA x S1 [mm]	DI [mm]	S3 [mm]	T [mm]	S3 [mm]	T [mm]	S3 [mm]	T [mm]
25	32 x 2,4	27,2					2,9	5,3
32	40 x 2,4	35,2					2,9	5,3
40	50 x 3,0	44					2,9	5,9
50	63 x 3,0	57					2,9	5,9
65	75 x 3,0	69					2,9	5,9
80	90 x 3,0	84					2,9	5,9
100	110 x 3,0	104			2,9	5,9	3,5	6,5
125	125 x 3,0	119			2,9	5,9	4,1	7,1
150	160 x 3,0	154	2,9	5,9	3,5	6,5	4,9	7,9
200	200 x 3,0	194	2,9	5,9	4,1	7,1	6,3	9,3
250	250 x 3,0	244	2,9	5,9	4,9	7,9	7,7	10,7
300	315 x 4,0	307	3,5	7,5	6,3	10,3	9,7	13,7
350	355 x 4,0	347	4,1	8,1	6,9	10,9	11,2	15,2
400	400 x 5,0	390	4,9	9,9	7,7	12,7	12,6	17,6
500	506 x 3,0	500	6,3	9,3	9,7	12,7	15,4	18,4
600	606 x 3,0	600	6,9	9,9	12,0	15,0	18,2	21,2
700	718 x 3,0	712	8,3	11,3	13,4	16,4		
800	806 x 3,0	800	9,1	12,1	15,4	18,4		
900	906 x 3,0	900	10,5	13,5	16,8	19,8		
1000	1006 x 3,0	1000	11,2	14,2	19,0	22,0		

S1 = thickness of thermoplastic liner
S3 = wall thickness of structural laminate
Slab with longitudinal weld

Calculation of pressed stub flanges according to EN 13121-3 / 2016. Possible stresses will not be considered. Safety factor $AxS = 6$. Flange connecting dimensions according to DIN EN 1092-1, PN 10. Wall thickness $DA \times s1$ and $S3$ according pipeline specification showed in the table below:

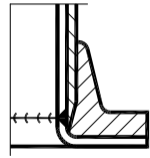
Work standard Pipeline	Liner Type	Type A	Type B
WN 4110	PP – kaschiert	25-300	
WN 4120	PE – kaschiert	25-300	
WN 4130	PVC – U	25-200 *	
WN 4140	PVC – C	25-200 *	
WN 4150	PVDF geätzt	25-150 *	
	ECTFE	25-150 *	

* DN 125 → Type B

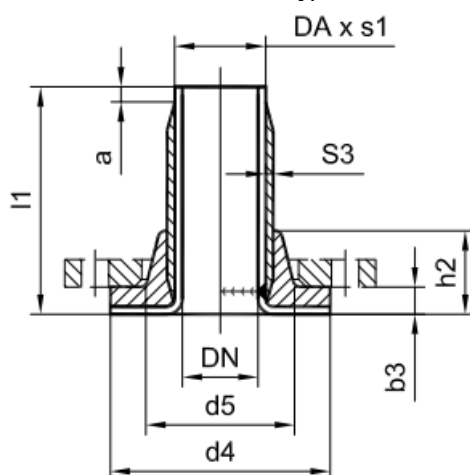

DN [mm]	d4 [mm]	d5 [mm]	l1 [mm]	h2 [mm]	PN 2,5 b3 [mm]	PN 6 b3 [mm]	PN10 b3 [mm]	PN16 b3 [mm]
25	68	50	150	37				16
32	78	58	150	39				18
40	88	68	150	44				18
50	102	82	150	44				18
65	122	95	150	50				19
80	138	111	150	56				20
100	158	133	150	63				22
125	188	160	200	70				24
150	212	188	200	77				26
200	268	237	200	95			29	
250	320	293	300	108			32	
300	370	343	300	141		34	41	
350	430	387	450	176		36	47	
400	482	441	450	147		39	48	
500	585	544	450	178	42	46	65	
600	685	648	500	209	44	53	76	

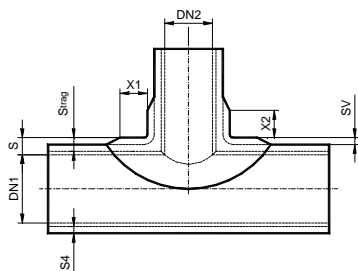

Typ 1

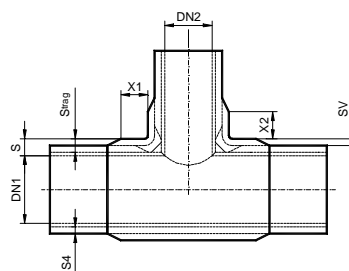

Typ 2

Wall thickness s4 [mm] according to 4110 – 4150-WN-en

		Laminate thickness s _v															
DN 2 [mm]	DN 1 [mm]	25	32	40	50	65	80	100	125	150	200	250	300	350	400	450	500
25	25	2,5	-	-	-	-	-	-	-	-	-	-	-	-	-	-	-
32	25	2,5	2,5	-	-	-	-	-	-	-	-	-	-	-	-	-	-
40	25	2,5	2,5	2,5	-	-	-	-	-	-	-	-	-	-	-	-	-
50	25	2,5	2,5	2,5	2,5	-	-	-	-	-	-	-	-	-	-	-	-
65	25	2,5	2,5	2,5	2,5	2,6	-	-	-	-	-	-	-	-	-	-	-
80	25	2,5	2,5	2,7	2,8	3,1	3,2	-	-	-	-	-	-	-	-	-	-
100	25	2,6	2,8	3,0	3,3	3,5	3,8	4,0	-	-	-	-	-	-	-	-	-
125	25	2,9	3,2	3,5	3,7	4,1	4,4	4,6	4,9	-	-	-	-	-	-	-	-
150	25	3,3	3,6	3,8	4,2	4,6	4,9	5,3	5,6	5,9	-	-	-	-	-	-	-
200	25	3,9	4,2	4,5	4,9	5,4	5,8	6,3	6,8	7,2	7,7	-	-	-	-	-	-
250	25	4,4	4,8	5,2	5,6	6,2	6,7	7,3	7,8	8,3	9,1	9,6	-	-	-	-	-
300	25	4,9	5,3	5,8	6,2	6,9	7,4	8,1	8,8	9,4	10,3	11,0	11,5	-	-	-	-
350	25	5,5	5,9	6,3	6,8	7,5	8,1	8,9	9,7	10,3	11,4	12,2	12,9	13,4	-	-	-
400	25	6,0	6,4	6,9	7,4	8,1	8,8	9,6	10,5	11,2	12,4	13,4	14,2	14,8	15,3	-	-
450	25	6,4	6,9	7,4	7,9	8,7	9,4	10,3	11,2	12,0	13,4	14,5	15,3	16,1	16,7	17,2	-
500	25	6,9	7,4	7,9	8,5	9,3	10,0	10,9	11,9	12,8	14,3	15,5	16,5	17,3	18,0	18,6	19,1

		Laminate width X1 and X2															
DN 2 [mm]	DN 1 [mm]	25	32	40	50	65	80	100	125	150	200	250	300	350	400	450	500
25	25	25	-	-	-	-	-	-	-	-	-	-	-	-	-	-	-
32	25	25	25	-	-	-	-	-	-	-	-	-	-	-	-	-	-
40	25	25	25	25	-	-	-	-	-	-	-	-	-	-	-	-	-
50	25	25	25	25	25	-	-	-	-	-	-	-	-	-	-	-	-
65	25	25	25	25	25	25	-	-	-	-	-	-	-	-	-	-	-
80	25	25	25	25	25	25	25	-	-	-	-	-	-	-	-	-	-
100	25	25	25	25	25	25	25	30	-	-	-	-	-	-	-	-	-
125	30	30	30	30	30	30	35	35	35	-	-	-	-	-	-	-	-
150	35	35	35	35	35	35	40	40	40	40	-	-	-	-	-	-	-
200	45	45	45	45	45	45	50	50	50	50	50	-	-	-	-	-	-
250	50	55	55	55	55	55	55	60	60	60	65	65	-	-	-	-	-
300	60	60	60	65	65	65	65	70	70	70	75	75	75	-	-	-	-
350	70	70	70	75	75	75	75	80	80	80	85	85	85	90	-	-	-
400	80	80	80	80	85	85	85	85	90	90	95	95	100	100	100	-	-
450	85	85	90	90	90	95	95	95	100	100	105	105	110	110	110	110	-
500	95	95	95	100	100	105	105	105	110	110	115	115	120	120	120	125	125

UP – resins based elbow 90°, glass reinforced with thermoplastic liner.
Wall thickness S3 [mm] according material certificate.
Mechanical layer according pipe class BK (see 1270-WN).

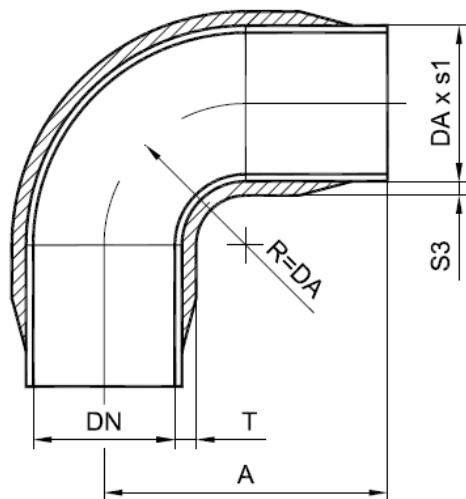

Type 1

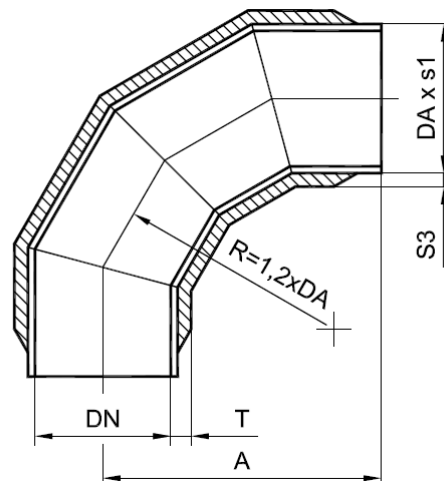

Type 2

PP fabric backed					PN6 [bar]		PN10 [bar]		PN16 [bar]	
DN	DA x S1 [mm]	SDR	DI [mm]	A	S3 [mm]	T [mm]	S3 [mm]	T [mm]	S3 [mm]	T [mm]
25	32 x 2,9	11	26,2	110					2,9	5,8
32	40 x 3,7	11	32,6	130					2,9	6,6
40	50 x 4,6	11	40,8	150					2,9	7,5
50	63 x 5,8	11	51,4	180					2,9	8,7
65	75 x 4,3	17,6	66,4	140					2,9	7,2
80	90 x 5,1	17,6	79,8	165					2,9	8,0
100	110 x 6,3	17,6	97,4	205			2,9	9,2	3,5	9,8
125	125 x 7,1	17,6	110,8	245			2,9	10,0	4,1	11,2
150	160 x 4,9	33	150,2	285	2,9	7,8	3,5	8,4	4,9	9,8
200	200 x 6,2	33	187,6	365	2,9	9,1	4,1	10,3	6,3	12,5
250	250 x 7,7	33	234,6	450	2,9	10,6	4,9	12,6	7,7	15,4
300	315 x 9,7	33	295,6	525	3,5	13,2	6,3	16,0	9,7	19,4
350	355 x 6,0	41	343,0	600	4,1	10,1	6,9	12,9	11,2	17,2
400	400 x 6,0	Lü.R.	388,0	680	4,9	10,9	7,7	13,7	12,6	18,6
500	508 x 4,0	PI.	500,0	830	6,3	10,3	9,7	13,7	15,4	19,4
600	608 x 4,0	PI.	600,0	950	6,9	10,9	12,0	16,0	18,2	22,2

UP – resins based elbow 90°, glass reinforced with thermoplastic liner.
Wall thickness S3 [mm] according material certificate.
Mechanical layer according pipe class BK (see 1270-WN).

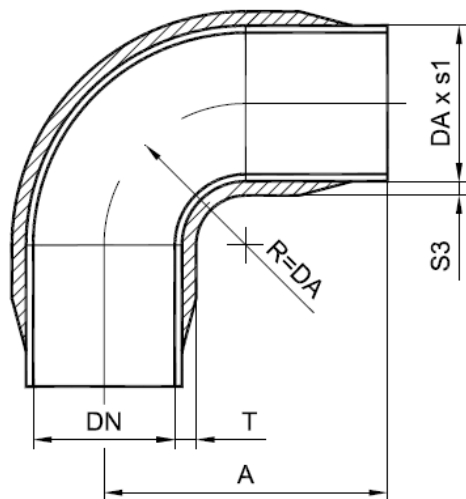

Type 1

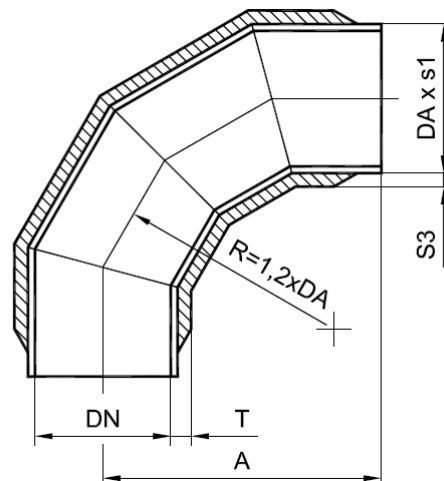

Type 2

PE fabric backed					PN6 [bar]		PN10 [bar]		PN16 [bar]	
DN	DA x S1 [mm]	SDR	DI [mm]	A	S3 [mm]	T [mm]	S3 [mm]	T [mm]	S3 [mm]	T [mm]
25	32 x 2,9	11	26,2	110					2,9	5,8
32	40 x 3,7	11	32,6	130					2,9	6,6
40	50 x 4,6	11	40,8	150					2,9	7,5
50	63 x 5,8	11	51,4	180					2,9	8,7
65	75 x 4,5	17,6	66,0	140					2,9	7,4
80	90 x 5,4	17,6	79,2	165					2,9	8,3
100	110 x 6,6	17,6	96,8	205			2,9	9,5	3,5	10,1
125	125 x 7,4	17,6	110,2	245			2,9	10,3	4,1	11,5
150	160 x 4,9	33	150,2	285	2,9	7,8	3,5	8,4	4,9	9,8
200	200 x 6,2	33	187,6	365	2,9	9,1	4,1	10,3	6,3	12,5
250	250 x 7,7	33	234,6	450	2,9	10,6	4,9	12,6	7,7	15,4
300	315 x 9,7	33	295,6	525	3,5	13,2	6,3	16,0	9,7	19,4
350	355 x 8,7	41	337,6	600	4,1	12,8	6,9	15,6	11,2	19,9
400	400 x 8,0	Lü.R.	380,0	680	4,9	12,9	7,7	15,7	12,6	20,6
500	508 x 4,0	PI.	500,0	830	6,3	10,3	9,7	13,7	15,4	19,4
600	608 x 4,0	PI.	600,0	950	6,9	10,9	12,0	16,0	18,2	22,2

UP – resins based elbow 90°, glass reinforced with thermoplastic liner.
Wall thickness S3 [mm] according material certificate.
Mechanical layer according pipe class BK (see 1270-WN).

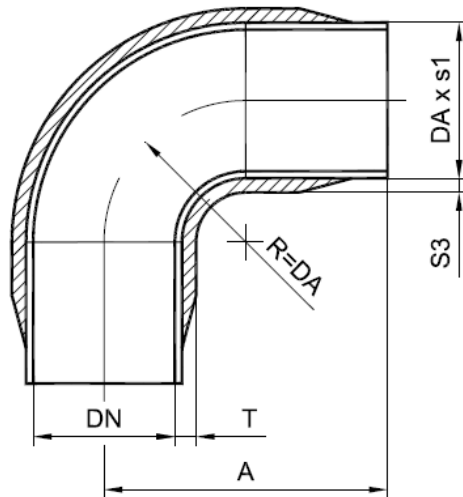

Type 1

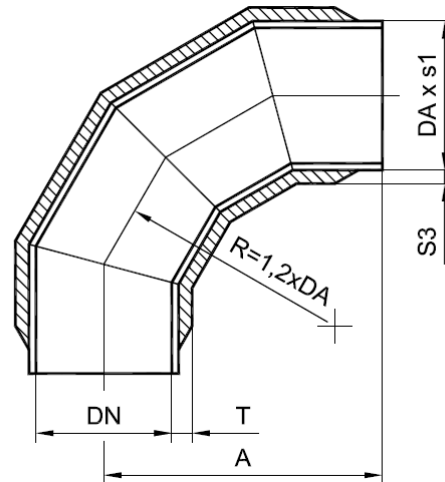

Type 2

PVC-U Pipe					PN6 [bar]		PN10 [bar]		PN16 [bar]	
DN	red DA x S1 [mm]	grey DA x S1 [mm]	DI [mm]	A	S3 [mm]	T [mm]	S3 [mm]	T [mm]	S3 [mm]	T [mm]
25	32 x 3,6	=	24,8	110					2,9	6,5
32	40 x 4,5	=	31	130					2,9	7,4
40	50 x 3,7	=	42,6	150					2,9	6,6
50	63 x 4,7	=	53,6	180					2,9	7,6
65	75 x 3,6	=	67,8	140					2,9	6,5
80	90 x 4,3	=	81,4	165					2,9	7,2
100	110 x 5,3	=	99,4	205			2,9	8,2	3,5	8,8
150	160 x 4,7	=	150,6	285	2,9	7,6	3,5	8,2	4,9	9,6
200	200 x 4,0	=	192	365	2,9	6,9	4,1	8,1	6,3	10,3
250	250 x 4,9	=	240,2	450	2,9	7,8	4,9	9,8	7,7	12,6
300	315 x 4,5	315 x 6,2	-	525	3,5	8,0	6,3	10,8	9,7	14,2
350	355 x 4,5	355 x 4,4	-	600	4,1	8,6	6,9	11,4	11,2	15,7
400	400 x 5,0	=	390	680	4,9	9,9	7,7	12,7	12,6	17,6
500	500 x 5,0	500 x 5,6	-	830	6,3	11,3	9,7	14,7	15,4	20,4
600	600 x 5,0	600 x 5,0	-	950	6,9	11,9	12,0	17,0	18,2	23,2

UP – resins based elbow 90°, glass reinforced with thermoplastic liner.
Wall thickness S3 [mm] according material certificate.
Mechanical layer according pipe class BK (see 1270-WN).

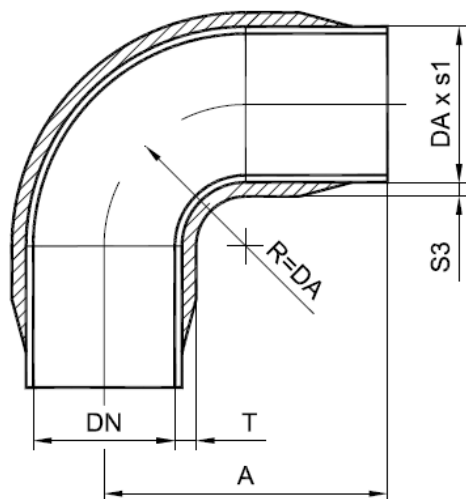

Type 1

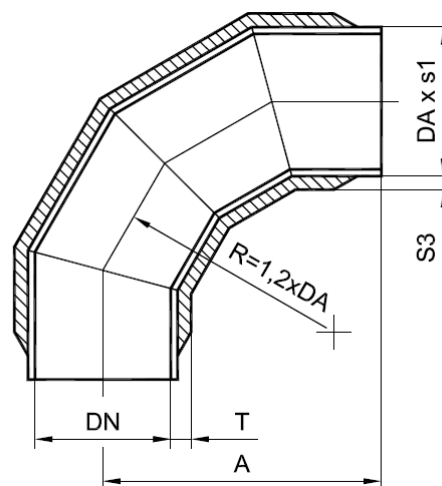

Type 2

PVC-C					PN6 [bar]		PN10 [bar]		PN16 [bar]	
DN	DA x S1 [mm]	SDR	DI [mm]	A	S3 [mm]	T [mm]	S3 [mm]	T [mm]	S3 [mm]	T [mm]
25	32 x 3,6	-	24,8	110					2,9	6,5
32	40 x 4,5	-	31,0	130					2,9	7,4
40	50 x 3,7	-	42,6	150					2,9	6,6
50	63 x 4,7	-	53,6	180					2,9	7,6
65	75 x 3,6	-	67,8	140					2,9	6,5
80	90 x 4,3	-	81,4	165					2,9	7,2
100	110 x 5,3	-	99,4	205			2,9	8,2	3,5	8,8
150	160 x 4,7	-	150,6	285	2,9	7,6	3,5	8,2	4,9	9,6
200	200 x 4,0	-	192,0	365	2,9	6,9	4,1	8,1	6,3	10,3
250	250 x 4,9	-	240,2	450	2,9	7,8	4,9	9,8	7,7	12,6
300	315 x 4,5	-	306,0	525	3,5	8,0	6,3	10,8	9,7	14,2
350	355 x 4,5	-	346,0	600	4,1	8,6	6,9	11,4	11,2	15,7
400	400 x 5,0	-	390,0	680	4,9	9,9	7,7	12,7	12,6	17,6
500	500 x 5,0	-	490,0	830	6,3	11,3	9,7	14,7	15,4	20,4
600	600 x 5,0	-	590,0	950	6,9	11,9	12,0	17,0	18,2	23,2

UP – resins based elbow 90°, glass reinforced with thermoplastic liner.
Wall thickness S3 [mm] according material certificate.
Mechanical layer according pipe class BK (see 1270-WN).

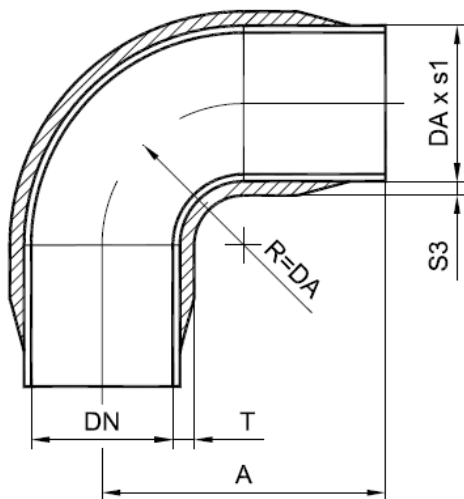

Type 1

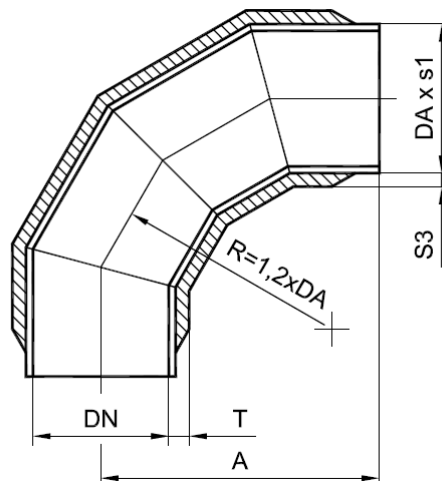

Type 2

PVDF geätzt					PN6 [bar]		PN10 [bar]		PN16 [bar]	
DN	DA x S1 [mm]	SDR	DI [mm]	A	S3 [mm]	T [mm]	S3 [mm]	T [mm]	S3 [mm]	T [mm]
25	32 x 2,4	-	27,2	110					2,9	5,3
32	40 x 2,4	-	35,2	130					2,9	5,3
40	50 x 3,0	-	44,0	150					2,9	5,9
50	63 x 3,0	-	57,0	180					2,9	5,9
65	75 x 3,0	-	69,0	140					2,9	5,9
80	90 x 3,0	-	84,0	165					2,9	5,9
100	110 x 3,0	-	104,0	205			2,9	5,9	3,5	6,5
125	125 x 3,0	-	119,0	245			2,9	5,9	4,1	7,1
150	160 x 3,0	-	154,0	285	2,9	5,9	3,5	6,5	4,9	7,9
200	200 x 3,0	-	194,0	365	2,9	5,9	4,1	7,1	6,3	9,3
250	250 x 3,0	-	244,0	450	2,9	5,9	4,9	7,9	7,7	10,7
300	315 x 4,0	-	307,0	525	3,5	7,5	6,3	10,3	9,7	13,7
350	355 x 4,0	-	347,0	600	4,1	8,1	6,9	10,9	11,2	15,2
400	400 x 5,0	-	390,0	680	4,9	9,9	7,7	12,7	12,6	17,6
500	506 x 3,0	-	500,0	830	6,3	9,3	9,7	12,7	15,4	18,4
600	606 x 3,0	-	600,0	950	6,9	9,9	12,0	15,0	18,2	21,2

Reducer laminate wall thickness according wall thickness of the larger pipe diameter.
See the work standards 4110, 4120,4130,4140 and 4150-WN-en.

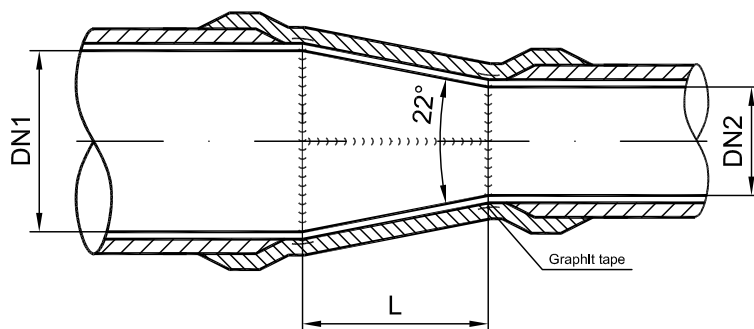

DN1 [mm]	DN2 [mm]	L [mm]
32	25	20
40	25	45
40	32	25
50	25	80
50	32	60
50	40	35
65	32	90
65	40	65
65	50	30
80	40	105
80	50	70
80	65	40
100	50	95
100	65	90
100	80	50
125	65	130
125	80	90
125	100	40
150	80	180
150	100	130
150	125	90
200	100	230
200	125	195
200	150	105

DN1 [mm]	DN2 [mm]	L [mm]
250	125	320
250	150	230
250	200	130
300	150	360
300	200	255
300	250	130
350	200	400
350	250	270
350	300	140
400	250	385
400	300	255
400	350	115

Reducer laminate wall thickness according wall thickness of the larger pipe diameter. See the work standards 4110, 4120,4130,4140 and 4150-WN-en.

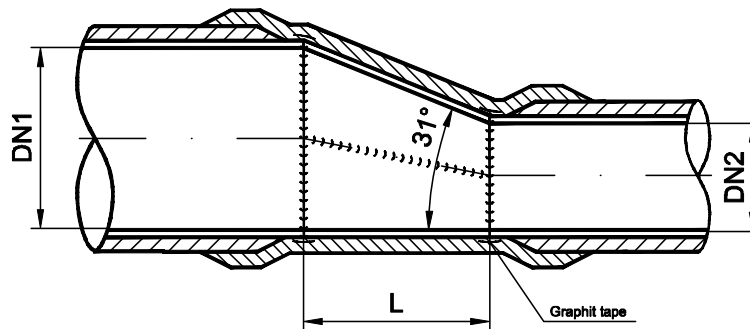

DN1 [mm]	DN2 [mm]	L [mm]
32	25	20
40	25	45
40	32	25
50	25	80
50	32	60
50	40	35
65	32	90
65	40	60
65	50	30
80	40	100
80	50	65
80	65	40
100	50	90
100	65	85
100	80	50
125	65	125
125	80	85
125	100	40
150	80	175
150	100	125
150	125	85
200	100	225
200	125	185
200	150	100

DN1 [mm]	DN2 [mm]	L [mm]
250	125	310
250	150	225
250	200	130
300	150	345
300	200	245
300	250	125
350	200	385
350	250	260
350	300	135
400	250	370
400	300	245
400	350	110

Flange connecting dimensions according to DIN 2501 Part 1, PN10

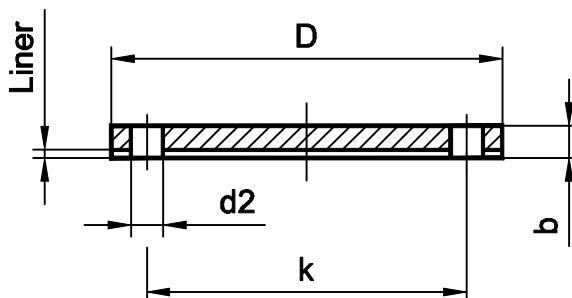

DN	D	k	d2	Number of drills	PN				
					2,5 [bar]	4 [bar]	6 [bar]	10 [bar]	16 [bar]
[mm]	[mm]	[mm]	[mm]		b [mm]	b [mm]	b [mm]	b [mm]	b [mm]
25	115	85	14	4					19
32	140	100	18	4					22
40	150	110	18	4					22
50	165	125	18	4					23
65	185	145	18	4					25
80	200	160	18	8				21	26
100	220	180	18	8				22	26
125	250	210	18	8			19	23	29
150	285	240	22	8			21	25	32
200	340	295	22	8		23	26	29	36
250	395	350	22	12		27	30	36	40
300	445	400	22	12	29	32	36	42	47
350	505	460	22	16	32	36	40	47	54
400	565	515	26	16	36	40	47	53	61
450	615	565	26	20	40	47	51	59	68
500	670	620	26	20	44	50	58	65	76
600	780	725	30	20	50	58	65	78	
712	895	840	30	24	59	68	78	90	
800	1015	950	33	24	65	76	86	100	
900	1115	1050	33	28	74	86	96	112	
1000	1230	1160	36	28	80	96	106	124	

In the specified wall thickness is 4 mm thick thermoplastic liner included.